

PRH103R

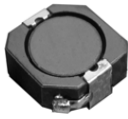

FEATURES 特点

- * Excellent solderability and high heat resistance
良好的可焊性和高耐热性

APPLICATION 用途

- * DC / DC 转换器

MEASURING FREQUENCY 测试频率

- * 100KHz 0.3V

Shapes And Dimensions 外形及尺寸示意图

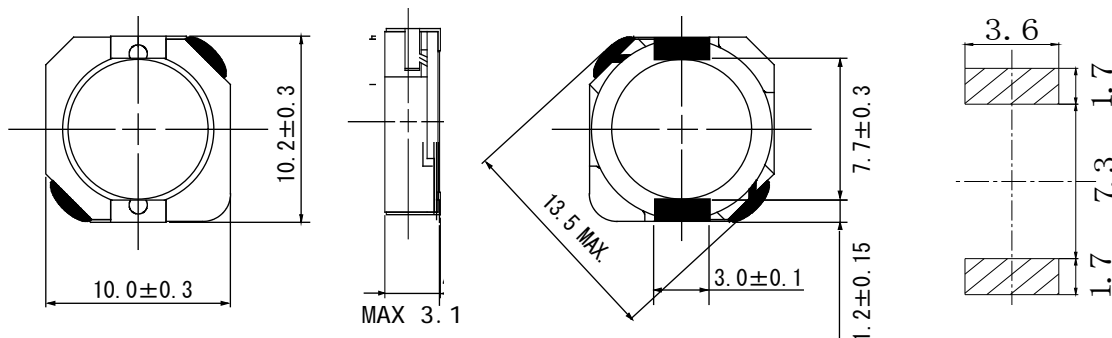

Electrical Characteristics 电气性能

Type 型號	Indicate 表示	Inductance 電感值	D.C.R(Max) 直流電阻(m)	Rated Current(Max) 額定電流(A)
PRH103 R-0R8	0R8	0.8 μ H \pm 30%	5.7(4.4)	11.20
PRH103 R-1R5	1R5	1.5 μ H \pm 30%	11.0(8.5)	8.00
PRH103 R-2R2	2R2	2.2 μ H \pm 30%	16.9(13)	6.70
PRH103 R-3R3	3R3	3.3 μ H \pm 30%	21.0(16)	5.56
PRH103 R-4R7	4R7	4.7 μ H \pm 30%	30.0(23)	4.65
PRH103 R-6R8	6R8	6.8 μ H \pm 30%	35.0(27)	3.84
PRH103 R-8R2	8R2	8.2 μ H \pm 30%	50.0(38)	3.54
PRH103 R-100	100	10 μ H \pm 30%	59.0(45)	3.18
PRH103 R-150	150	15 μ H \pm 30%	91.0(70)	2.60
PRH103 R-220	220	22 μ H \pm 30%	143(110)	2.16
PRH103 R-330	330	33 μ H \pm 30%	202(155)	1.74
PRH103 R-470	470	47 μ H \pm 30%	299(230)	1.43
PRH103 R-560	560	56 μ H \pm 30%	325(250)	1.36
PRH103 R-680	680	68 μ H \pm 30%	429(330)	1.22
PRH103 R-820	820	82 μ H \pm 30%	494(380)	1.14
PRH103 R-101	101	100 μ H \pm 30%	683(525)	1.02
PRH103 R-121	121	120 μ H \pm 30%	754(580)	0.89
PRH103 R-151	151	150 μ H \pm 30%	871(670)	0.84

* SPQ:1000PCS/REEL